

Tous droits strictement réservés. Reproduction ou communication à des tiers interdite sous quelque forme que ce soit sans autorisation écrite du propriétaire. Propriété de c.FCI. Droits de reproduction FCI.

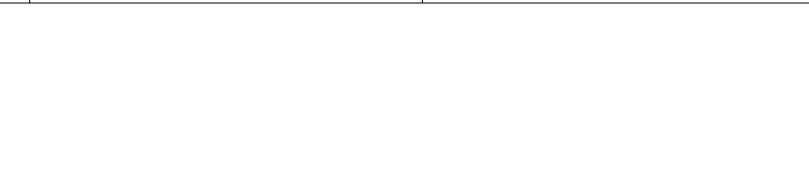

All rights strictly reserved. Reproduction or issue to third parties in any form whatever is not permitted without written authority from the proprietor. Property of FCI. Copyright FCI.

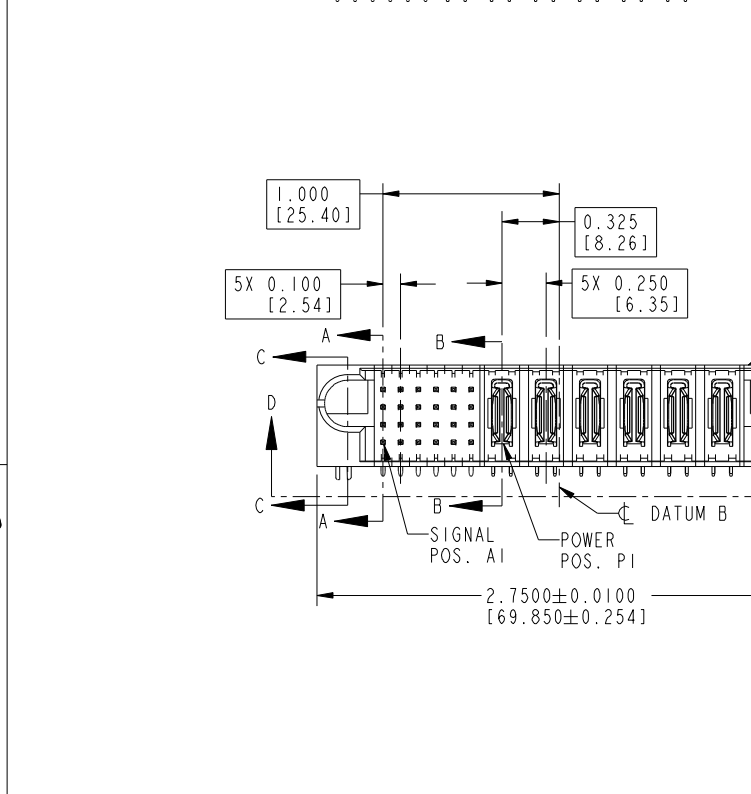
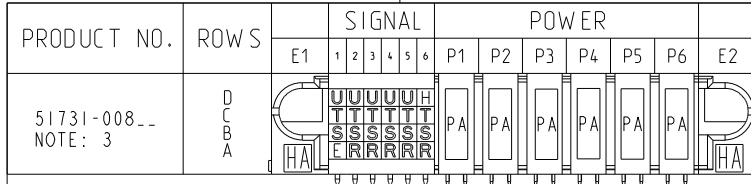

CODE	DIM "M" MATING LENGTH	DIM "T" TAIL LENGTH	CONTACT TYPE
PA	N/A [N/A]	0.135 [3.43]	POWER
HA	N/A [N/A]	N/A [N/A]	HOLD-DOWN
U	0.270 [6.86]	0.135 [3.43]	SIGNAL
T	0.270 [6.86]	0.135 [3.43]	SIGNAL
S	0.270 [6.86]	0.135 [3.43]	SIGNAL
E	0.220 [5.59]	0.135 [3.43]	SIGNAL
R	0.270 [6.86]	0.135 [3.43]	SIGNAL
H	0.220 [5.59]	0.135 [3.43]	SIGNAL

mat'l code				SEE NOTE 2		tolerances unless otherwise specified		CUSTOMER	
ltr	ecn no.	dr	date	linear	.XX±.01/0.X±0.3	angles	0°±2°	copy	projection
A	V12504	JWS	10/17/01		.XXX±.005/0.XX±0.13				
B	V12523	JWS	11/7/01		.XXX±.0020/0.XXX±0.051				
C	DG05-0458	GuoJM	11/17/05						
D	DG08-0253	SH	09/13/08	dr	J. SHAFFER	enr	J. ALLISON	chr	J. ALLISON
				appr	J. ALLISON		J. ALLISON		J. ALLISON

www.fciconnect.com		title		product family		code	
COPY		24S + 6P		PwrBlade		210	
INCH/MM		RIGHT ANGLE SOLDER HEADER		size		sheet	
scale		A		51731-008		1 of 4	

sheet index	revision sheet	D	D	D	D
		1	2	3	4

Pro/E

cage code 22526

Tous droits strictement réservés. Reproduction ou communication à des tiers interdite sous quelque forme que ce soit sans autorisation écrite du propriétaire. Propriété de c.FCI. Droits de reproduction FCI.

All rights strictly reserved. Reproduction or issue to third parties in any form whatever is not permitted without written authority from the proprietor. Property of FCI. Copyright FCI.

PRODUCT NUMBER
51731-008--
NOTE: 3

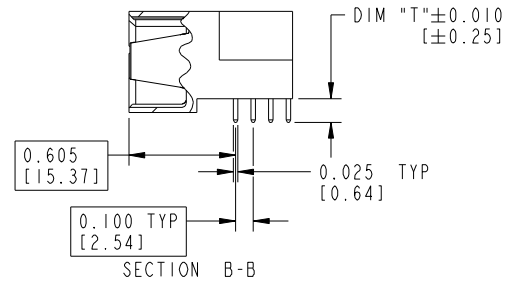
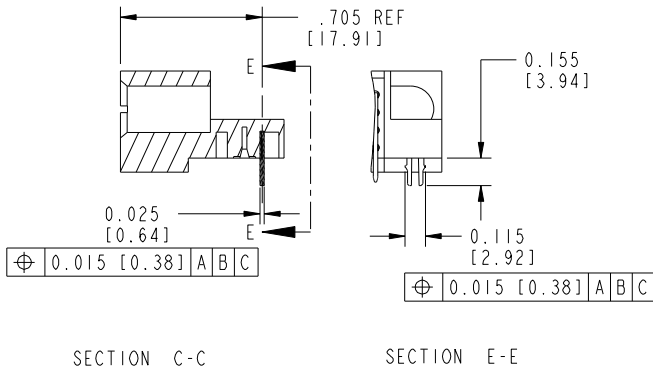
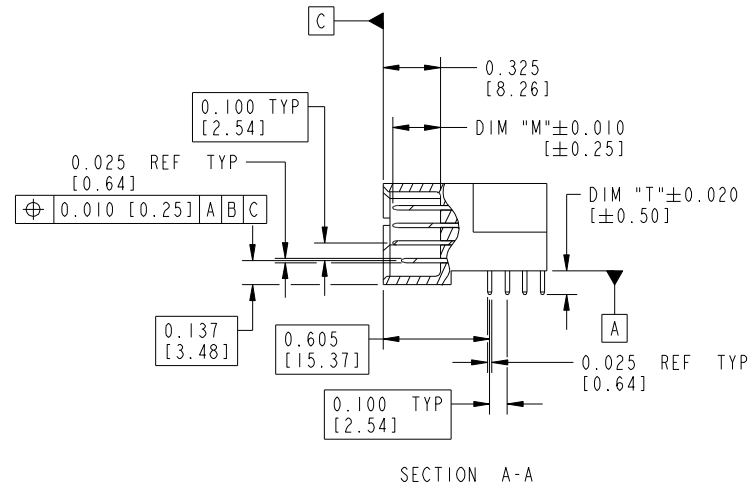
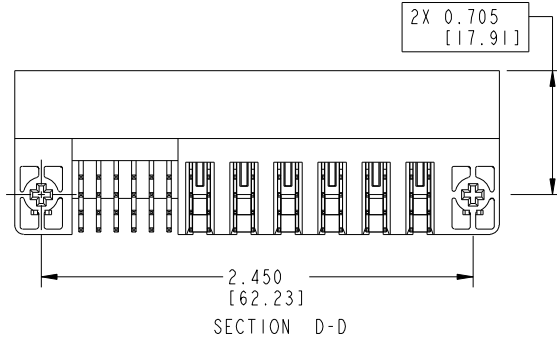

mat'l code				SEE NOTE 2		tolerances unless otherwise specified		CUSTOMER		FCI	
ltr	ecn no.	dr	date	linear	.XX±.01/0.X±0.3	projection	COPY	www.fciconnect.com			
D					.XXX±.005/0.XX±0.13			title 24S + 6P			
				angles	.XXX±.0020/0.XXX±0.051			RIGHT ANGLE SOLDER HEADER			
				dr	0°±2°			product family PwrBlade		code 210	
				enr	J. SHAFFER 10/17/01			size dwg no		sheet 2 of 4	
				chr	J. ALLISON 10/17/01			A 51731-008			
				appd	J. ALLISON 10/17/01			scale 1:1			
sheet index		revision sheet									

Pro/E

cage code 22526

Tous droits strictement réservés. Reproduction ou communication à des tiers interdite sous quelque forme que ce soit sans autorisation écrite du propriétaire. Propriété de c.FCI. Droits de reproduction FCI.



All rights strictly reserved. Reproduction or issue to third parties in any form whatever is not permitted without written authority from the proprietor. Property of FCI. Copyright FCI.

PRODUCT NUMBER
51731-008--
NOTE: 3

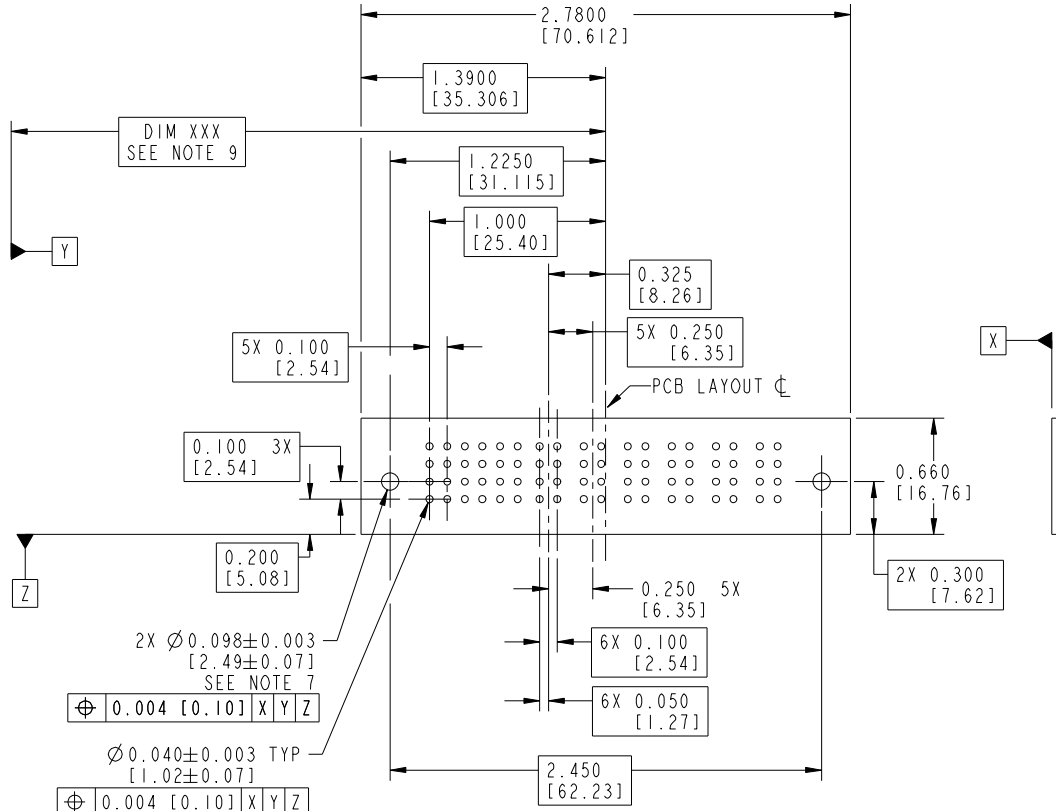

RECOMMENDED PCB LAYOUT

mat'l code		SEE NOTE 2		tolerances unless otherwise specified		CUSTOMER		 www.fciconnect.com	
ltr	ecn no.	dr	date	linear	.XX±.01/0.X±0.3	COPY		title	
D					.XXX±.005/0.XX±0.13	projection		24S + 6P	
				angles	.XXX±.0020/0.XXX±0.051			RIGHT ANGLE SOLDER HEADER	
				dr	0°±?	INCH/MM		product family	
				enr	J. SHAFFER 10/17/01	scale		PwrBlade	
				chr	J. ALLISON 10/17/01	1:1		code	
				appd	J. ALLISON 10/17/01	size		210	
sheet index		revision sheet				dwg no		sheet	
						A		3 of 4	
						51731-008			

cage code 22526

Tous droits strictement reserves. Reproduction ou communication a des tiers interdite sous quelque forme que ce soit sans autorisation écrite du propriétaire. Propriete de c FCI. Droits de reproduction FCI.



All rights strictly reserved. Reproduction or issue to third parties in any form whatever is not permitted without written authority from the proprietor. Property of FCI. Copyright FCI.

PRODUCT NUMBER
51731-008_
NOTE:: 3

NOTES:

- DIMENSIONS AND TOLERANCES ARE IN ACCORDANCE WITH ASME Y14.5M, 1994 UNLESS OTHERWISE SPECIFIED.
 - HOUSING MATERIAL: UL 94 V-0 GLASS FILLED HIGH TEMP THERMOPLASTIC
POWER CONTACT MATERIAL: COPPER ALLOY
SIGNAL CONTACT MATERIAL: COPPER ALLOY
 - PLATING:
⚠ SEE ITEM 1 & 2 IN PRINT 10064183 FOR PLATING SPEC OF 51731-008 AND 51731-008LF RESPECTIVELY
 - "MANUFACTURER" NAME, P/N, AND DATE CODE TO APPEAR ON THIS SURFACE
 - PRODUCT SPECIFICATION GS-12-149
- PCB NOTES:
- ALL HOLE DIAMETERS ARE FINISHED HOLE SIZE.
 - HOLD DOWN THROUGH HOLES ARE UNPLATED.
 - $\varnothing 0.0453 \pm 0.0010$ [1.151 ± 0.025] DRILLED HOLES PLATED WITH 0.0003 [0.008] MIN SnPb OVER 0.001 [0.03] TO 0.003 [0.08] Cu PLATING TO ACHIEVE A $\varnothing 0.040 \pm 0.003$ [1.02 ± 0.07] HOLE.
 - "DIM XXX" TO BE DETERMINED BY THE CUSTOMER
 - A ⚠ SYMBOL WILL BE NEXT TO ANY DIMENSION, VIEW, OR NOTE WHICH HAS BEEN MODIFIED WITH CURRENT DRAWING VERSION.

mat'l code		SEE NOTE 2		tolerances unless otherwise specified		CUSTOMER		FCI		www.fciconnect.com	
ltr	ecn no.	dr	date	linear	.XX±.01/0.X±0.3	COPY		projection			
D					.XXX±.005/0.XX±0.13	⊕ ←		title 24S + 6P			
				angles	.XXX±.0020/0.XXX±0.051	INCH/MM		RIGHT ANGLE SOLDER HEADER			
				dr	0°±2°	scale		product family PwrBlade		code	
				enr	J. SHAFFER 10/17/01	1:1		size		210	
				chr	J. ALLISON 10/17/01	A		dwg no		sheet	
				appd	J. ALLISON 10/17/01			51731-008		4 of 4	
sheet index		revision sheet									

cage code 22526

Pro/E